



INSTALLATION INSTRUCTIONS

[CARBAHN.COM/INSTRUCTIONS](https://carbahn.com/instructions)

MERCEDES AMG C63/C63S FRONT CASTER ADJUSTER

**CARBAHN PART #:
CBC63-3101**



US Based Support
866-558-4314
Sales@CarBahn.com
CarBahn.com

Info

Kit ID: CBC63-3101

Version: 1.1.2

Date Published: June 7th, 2020

Warnings

- ⓘ If not used and installed properly this component can significantly affect the performance and drivability of the vehicle.
- ⓘ Use secure jack stands, do not work on vehicles supported by a jack only.
- ⓘ Re-aligning the car after installation is required to fully utilize the kit and not affect drivability, only use the BMW recommended alignment.
- ⓘ Please only use recommended BMW procedure for working on the car and installing these parts.

Inside the Box

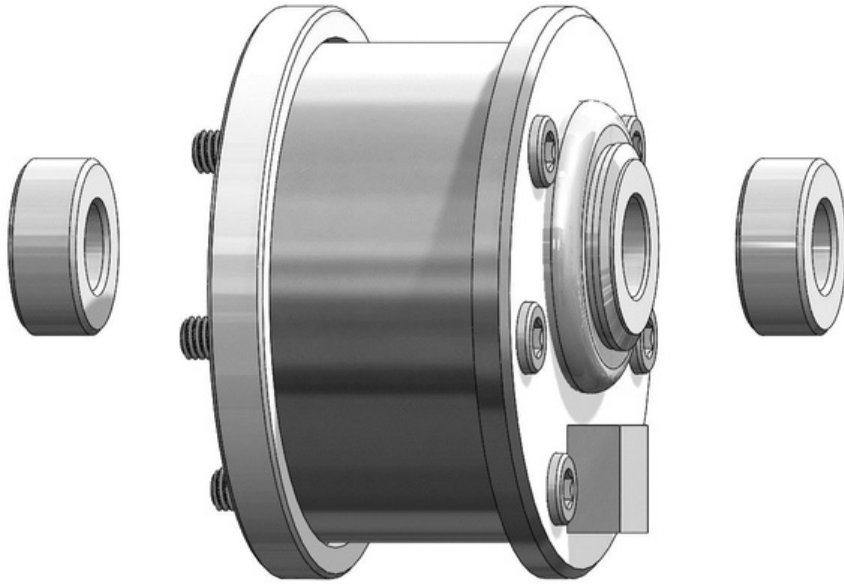

Front Caster Adjuster Kit CBC63-3101

Installation

1. Remove the left and right stock front caster arm.
 2. Set aside the washers, nuts and bolts for the caster arms as they will be used again. Be sure to re-use factory hardware in their original locations.
 3. Press out the stock rubber bushing from the stock caster arms as per the Mercedes recommended procedure.
 4. Apply grease to the internal face of the inboard side of the arm and slide in the Main Housing Assembly from the outside face of the caster arm. CarBahn caster adjuster kit is made to slide easily into the caster arm.
 5. To adjust caster arm safely please read the warning below.
- ⚠ Warning:** To adjust caster safely and to make sure there is no interference please make sure the center of the bushing is always in the upper 180 degrees of the assembly as shown:

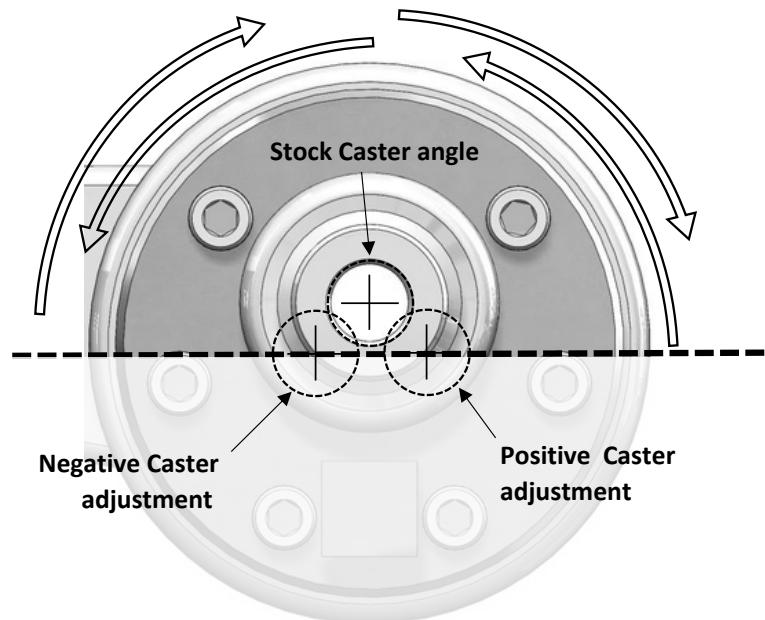

6. Assemble the caster arm as shown in the picture below. Torque the bolts to 120 pounds-in.

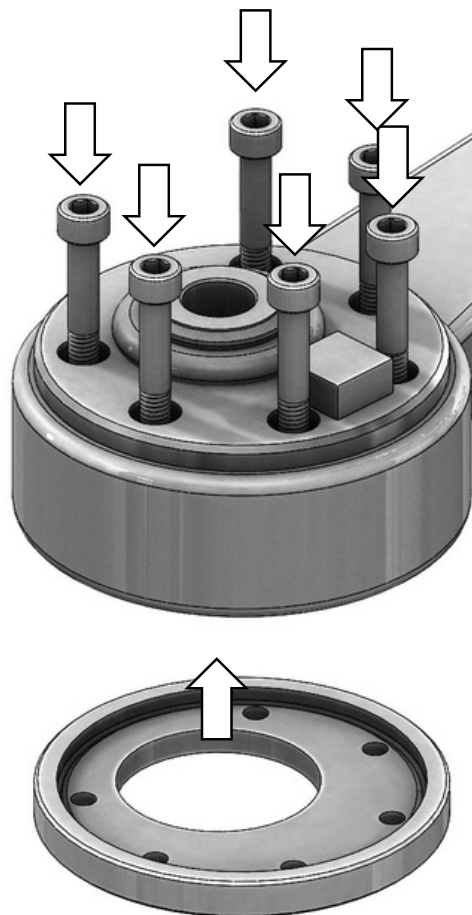

7. Once the assembly is complete, reassemble the Caster adjuster arms using the spacers as shown on the next page.

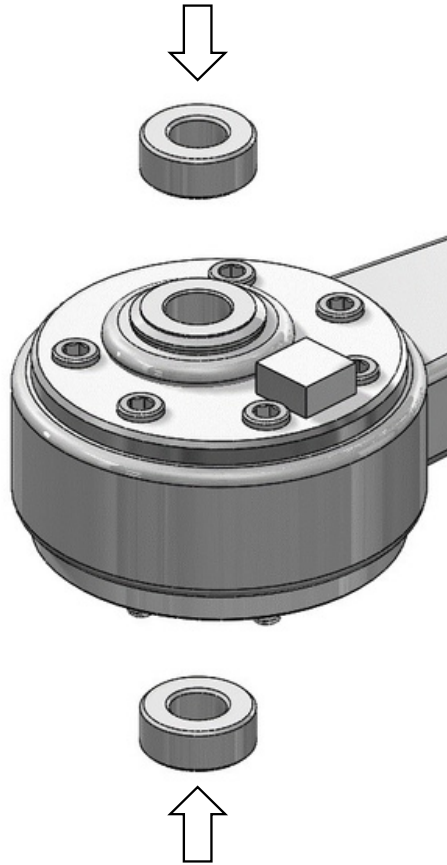

8. Use the stock hardware to secure the assembly to the chassis as per the Mercedes recommended procedure.
9. Perform an alignment after installing the front caster adjuster kit. Lowering the inboard side of the caster arm will be necessary to reiterate the caster angle.